

KGR SD-10 Hammer Parts Details

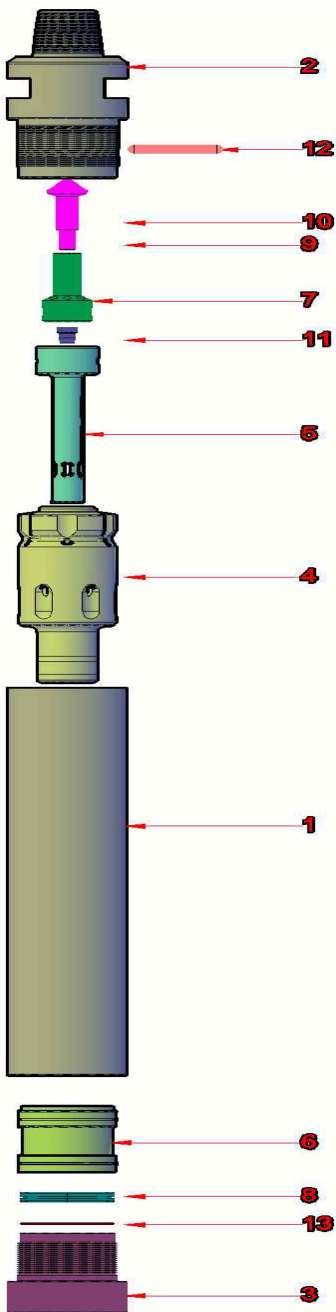

S.No	Replacement parts item Description	Weight in Kg
1	Hammer Case	78
2	Top Sub with 6 5/8" API IF. Pin	57
3	Front Chuck	16.2
4	Piston	45.10
5	Control tube	3.1
6	Guide Bush	12.3
7	Top Valve	2.5
8	Bit Retainer Ring	1.9
9	Spring	0.08
10	Check Valve	0.8
11	Choke	0.05
12	Coupler Pin	0.7
13	O ring for Bit retainer ring	0.008

BIT SHANK

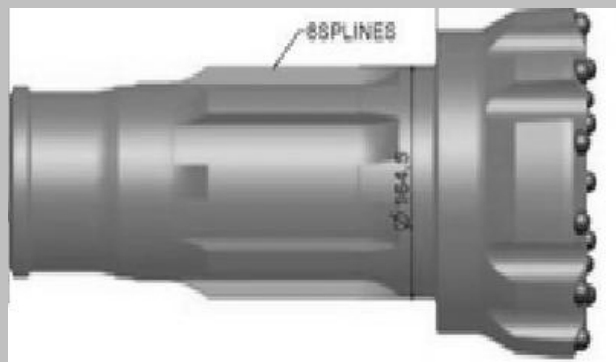

Weight		Outside diameter		Hammer length	
kg	lb	mm	inch	mm	inch
218	480	225	8.85	1220	48

Air consumption, cfm					Air consumption, m3/min				
150psi		250psi		350psi	10 bar		18 bar		24 bar
Min	Max	Min	Max	-	Min	Max	Min	Max	-
650	1080	1230	1690	-	18.5	30.6	35.0	47.5	-